

HYUNDAI
POWER PRODUCTS

GENERATOR PETROL INVERTER HG3000I

ORIGINAL INSTRUCTIONS

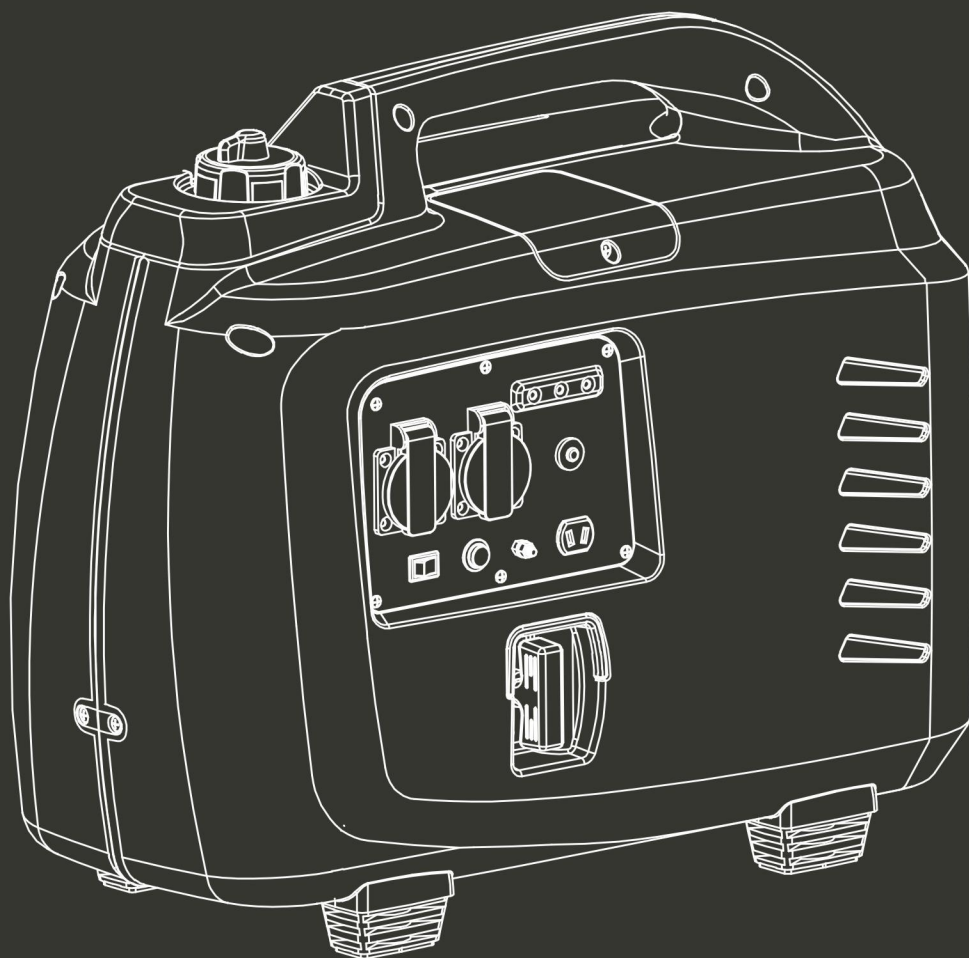

WARNING: Read thoroughly the instruction manual before use.

CONTENT

1. Warnings for safety operation.....	3
2. Quick Start	7
3. Safety Precautions label position.....	9
4. Parts Identification.....	10
5. Pre flight checks.....	11
6. Start the engine.....	14
7. Use of the generator.....	16
8. Switch off the engine.....	22
9. Maintenance	23
10. Transportation/Warehousing.....	30
11. Troubleshooting.....	31
12. Specifications.....	33
13. CE declaration.....	34
14. WARRNTY	35
15. PRODUCT FAILURE	36
16. WARRANTY EXCLUSIONS.....	37

1. Warnings for safety operation



General security instructions

- The operator must know the principles of functioning and the structure of the generator and the motor. He must know how to stop the motor in case of urgency and how to manipulate the controls.
- Never let children use this device.
- Never let people who do not know these instructions use this device. Local regulations may impose restrictions on the age of the user.
- Please do not use this device when people, especially children, or pets are nearby. Direct them away from the working area.
- The operator or the user are responsible for possible accidents or damage to other persons or to their property.
- Do not wear loose clothing or jewellery as this can get caught in the machinery as it runs.
- Use safety equipment. Wear protective gear such as an anti-dust mask, non-slip safety shoes, a helmet or hearing protection.
- Stay vigilant, watch what you are doing and show good sense when you use the generator. Do not use if you are tired or under the influence of drugs, alcohol or medicines.
- Install the generator in a place that is well ventilated and make sure that there is at least 1.5 metres between the generator and the walls of the building or other equipment. Do not place flammable liquids or gases near the generator.
- Do not run the generator in an enclosed or badly-ventilated space. The exhaust gas from the motor contains carbon monoxide which is toxic and may lead to a loss of consciousness or death.
- Run the generator in respect of the power indicated in the user's manual. Do not run the generator with an overload or at excessive speed.
- The silencer of the generator becomes extremely hot when the motor runs or even for a time after it has stopped. Do not touch it as it will burn you.
- Do not transport or move the generator until it has cooled down.
- Perform periodic maintenance and resolve problems that appear immediately. Do not run the generator before correcting any fault detected.
- The generator uses a system of air-cooling, and it is necessary to clean its components regularly, including the grilles, the cover of the fan and the fan itself so as to ensure cooling.
- Keep the fuel filter clean, and change the oil of the motor regularly.

- Periodically check the installation of the connections and the tightness of the fixations, re-tightening them if necessary.
- Clean the components of the air filter periodically, and replace the air filter when necessary.
- Remove any electrical equipment that is plugged in before starting or stopping the generator.
- Before transporting the generator, you must empty the fuel tank.
- Maintenance and repair of the generator must be carried out by a qualified technician from an authorised after-sales service centre.

Warning: when you start the generator with the cord, watch out for sudden changes in the rotation of the motor!!! Risk of wounding!!! Never cover the generator when it is running. The cut-out mounted on the generator has the aim of reducing the risk of electric shock. If it needs to be replaced with another cut-out, the latter must correspond to the technical specifications of the generator. Due to important mechanical constraints, it is necessary to use a flexible sheathed cable with a strong rubber protective layer (conforming to IEC 245-4) or a similar cable. If using an electrical extension cable, the total length of the extension must not exceed 60m when the section of the wire is 1.5mm² and must not exceed 100m when the section of the wire is 2.5mm².



Security measures when filling the fuel tank

The fuel is extremely flammable and poisonous.

- This generator only uses petrol (gasoline); any other kind of fuel will damage the motor.
- Do not overfill the tank with petrol to avoid spilling. If you notice a spill, it must be wiped up completely with a dry cloth before starting the motor.
- If you swallow fuel by mistake, if you inhale fuel vapours or if you get drops of fuel in your eyes, see a doctor immediately. If a certain quantity of fuel is spilt on your skin or clothing, wash or change your clothes.
- Always stop the motor of the generator when filling it with fuel.
- Never fill the fuel tank while smoking or near a naked flame.
- Make sure you don't spill fuel on the motor and the exhaust grille of the generator during filling with fuel.
- Keep the fuel in an appropriate recipient and sheltered from any sources of fire.

- Carry out filling in a safe place, and slowly open the fuel cap to release the pressure which has built up inside the tank. Wipe up any drops of petrol that have spilled before starting the motor.
- To prevent fire, move the generator at least 4 metres away from the area for filling with fuel.
- Make sure that the fuel cap is tightly closed before starting.
- Do not keep petrol in the tank for a long time.
- While using or transporting the generator, make sure you keep the generator upright, otherwise the fuel may escape from the carburettor or the fuel tank.



Electrical safety



Before each use ensure that the load to be connected does not exceed the power of the current produced by the generator.

To avoid electric shock, you must follow the following instructions:

- Do not touch the generator with wet hands.
- Do not run the generator under rain or snow.
- Do not run the generator near water.
- Connect the generator to earth. Use a sufficiently thick conductor for the earth wire.
- Do not operate the generator in parallel with another generator.
- If using electrical extensions, make sure that they are sufficiently thick to transport the current and that they are used correctly.



The connection of a generator used for auxiliary power to the electrical installation of a building must be performed by a qualified electrician, and in conformity to the provisions of the applicable laws and norms in the field of electricity. Incorrect connections will cause leakage of the current from the generator into the lines of the public electricity company. Such leakage could electrocute the workers of the public electricity company working on the network or other persons in contact with the line during a power cut.



Also, when the public power supply is re-established, the generator can explode, catch fire or generate fires in the building's electrical installation.

Before connecting electrical devices to the generator, make sure that their voltage specifications and frequency of functioning correspond to the technical characteristics of the generator. There may be damage if the device connected is not designed to function with a voltage tolerance of +/- 10% or a frequency tolerance of +/- 3 %

















compared with those of the generator.

Protection of the environment

- You must periodically check the silencer (Before doing this, switch off the generator and let it cool completely). A damaged silencer increases noise.
- Do not throw motor oil into the drains but deposit it at a collection point set up for that purpose.
- The fuel for this machine is combustible and explosive. After stopping the machine, you must handle the remaining fuel correctly and meet local environmental requirements.

Warning symbols explanation

	This is the safety alert symbol. It is used to warn you of a risk of injury and material damage. Observe all safety messages following this symbol to avoid possible injury or even death or damage to the equipment.
	To reduce the risk of personal injury and property damage, the user must read and understand this manual before using this product.
	It is forbidden to run the generator in an enclosed room because exhaust emissions can lead humans or animals to coma to death.
	This symbol indicates the surface is very hot and not touching
	Keep away from the machine
 	Exhaust emissions are harmful to health of body
 	No naked fire near the machine!
	Do not connect with the electricity system.
 	Do not dispose of old appliances with household waste.
	Complies with the corresponding Europe safety standards.
	Declaration sound power level according to directive 2000/14/EC
	Risk of electric shock

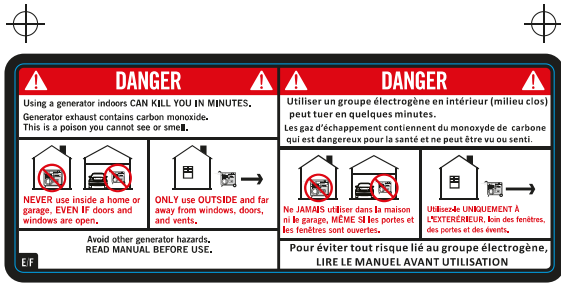

■ PMS 485C
■ BLACK

181 mm x 70 mm

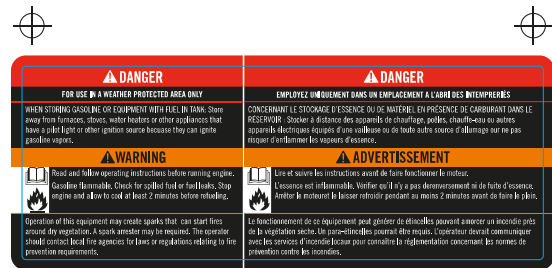

■ PMS 485C
■ PMS 152C
■ BLACK

175 mm x 65 mm

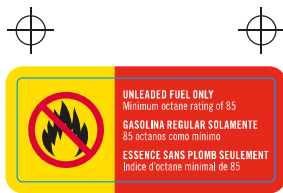

■ PMS 485C
■ PMS 109C
■ BLACK

72 mm x 29 mm



■ PMS 152C
■ BLACK

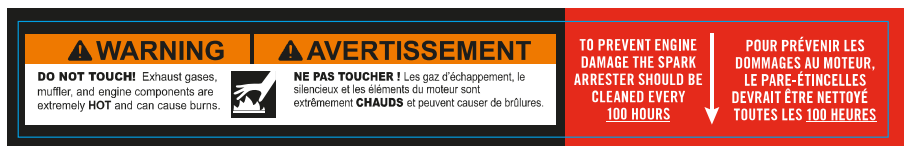

2. Quick start

⚠ Warning

- ◆ Only active outdoors. Generator of toxic carbon monoxide, a colorless, odorless gas that can cause death or serious injury.
- ◆ To ensure that the generator is placed horizontally.
- ◆ Can not work in the rain, snow or other humid environments.
- ◆ Refuel away from cigarettes, sparks to avoid fire or explosion.

Checks before start

1. Remove the oil access door, unscrew the dipstick to check the oil. If oil level is below the bottom of the dipstick, add the recommended oil (oil capacity: 0.45L). Use a strong detergency, four-stroke engine oil and choose proper viscosity of the oil according to your area's average temperature.
2. Install side access panel.
3. Unscrew the fuel tank cap to add gasoline to the fuel tank. Please use unleaded

petrol or above 87 # gasoline. Not add too fast, so as not to spill gasoline. And to prevent dirt, dust or water into the tank. Tighten the fuel tank cap after the addition was complete.

⚠ Be careful

- ◆ Do not use two-stroke gasoline or dirty gasoline.

Start the generator

4. In the following way to start the generator.
 - A. Recoil start:
 - i. Open the fuel switch.
 - ii. Turn The fuel cap and ventilate knob to the "ON" position
 - iii. Turn on the start switch.
 - iv. Gently pull the lever to start to feel resistance, then quickly pulled the handle to start, start the generator.
5. When the output indicator lights on the control panel, the generator can be used. Before connecting any load, the generator should be grounded. Please use a thick cable to the ground terminal on the generator control panel is connected to an external ground source.
6. Make sure all equipment is turned off and the switch in order to ensure that the equipment is intact, confirm the use of electrical appliances does not exceed the total power rating of the generator.
7. Connect your device to a suitable outlet generator control panel.

Turn off Generator

⚠ Note

- ◆ In any case, turn off the start switch on the control panel, the generator will stop immediately.

1. Turn off the generator in the following manner.
 - i. Turn off the connected device switch, unplug it.
 - ii. Turn off start switch.
 - iii. Close fuel switch.
 - iv. Turn The fuel cap and ventilate knob to the "OFF" position

3. Safety Precautions label position

These decals tips you may cause serious injury accidents.

Please read this manual mentioned decals, safety and caution carefully.

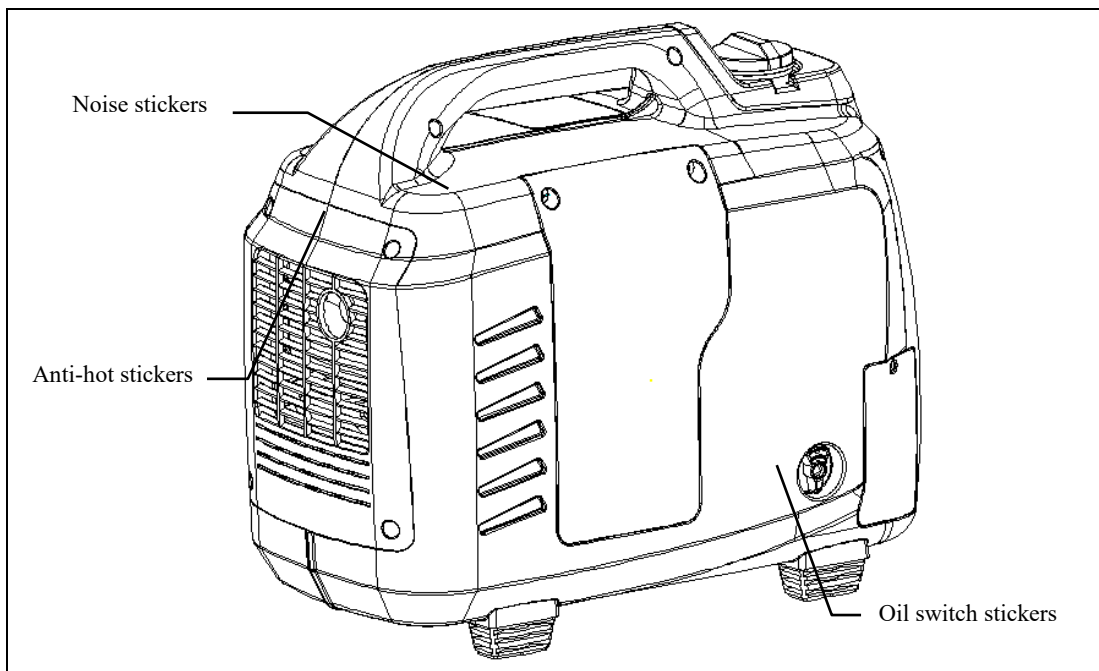
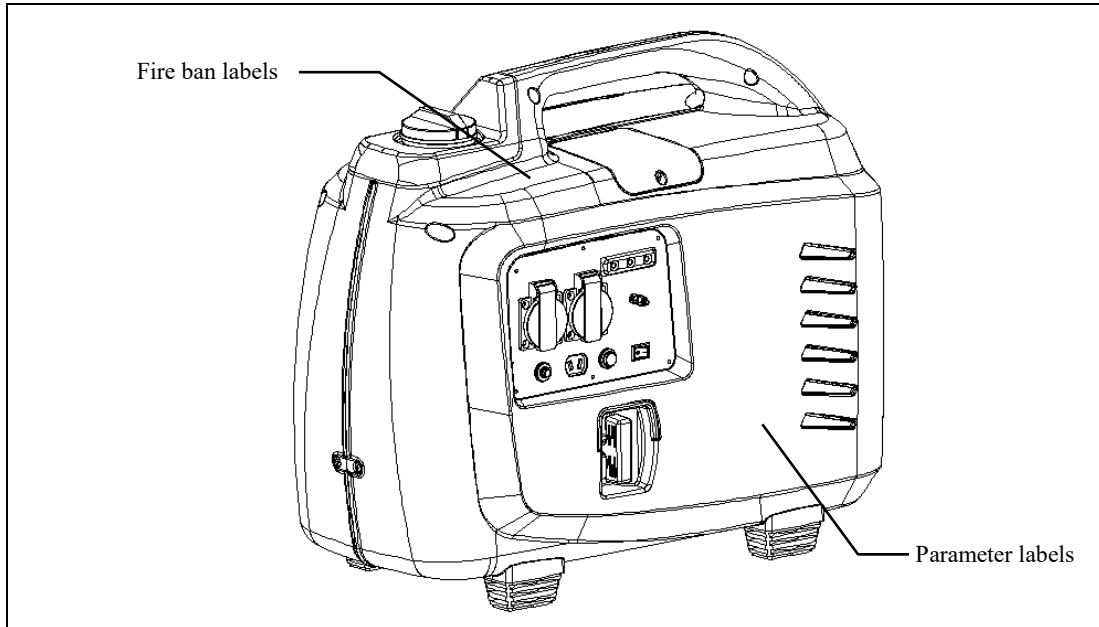

4. Parts Identification

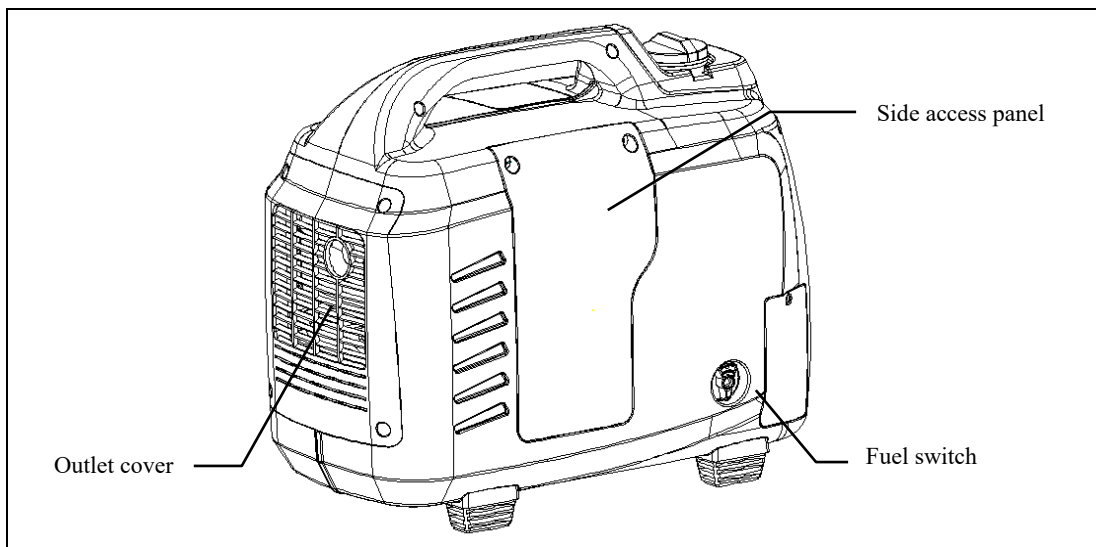
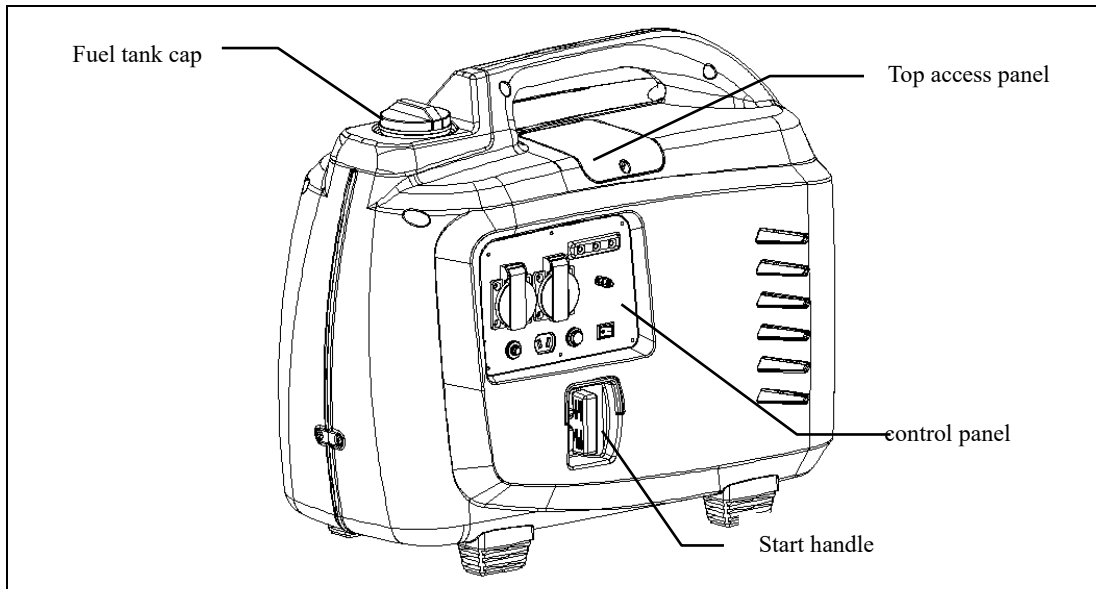

Control panel

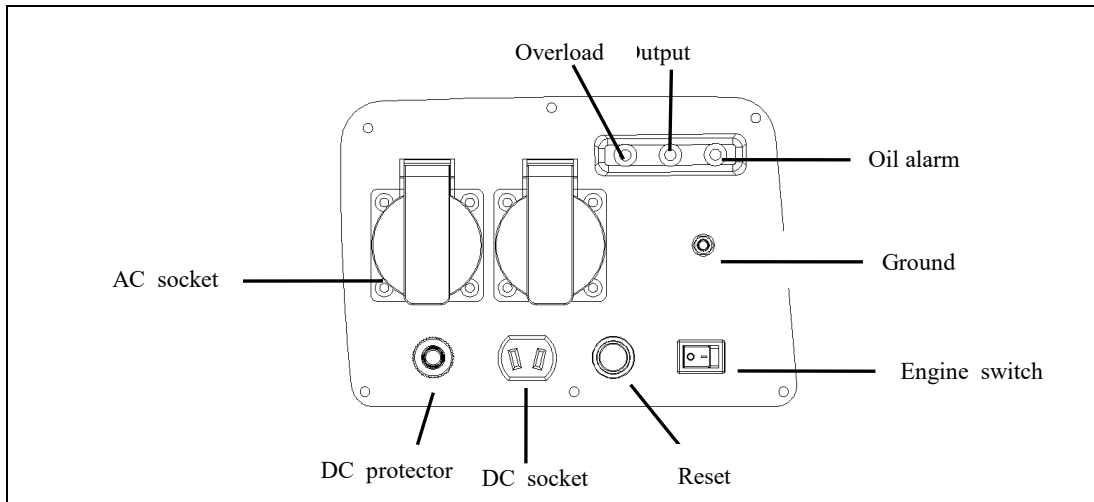

5. Pre flight checks

⚠ Be careful

- ◆ Be sure to check whether the generator level place, whether the engine is turned off.

1. Check the oil level

⚠ Be careful

- ◆ Use non-detergency oil or 2-stroke engine oil could shorten the engine life.
- ◆ Use a strong detergency, high-quality 4-stroke engine oil, which must meet or exceed US automobile manufacturer's requirements of the American Petroleum Institute classification SG, SF levels.
- ◆ Select the appropriate viscosity of the oil according to the average temperature in your area.

SEA viscosity grade as follows:

Single Viscosity	10W					
	20W					
	20					
	30					
	40					→
Multi-viscosity	20W-40, 20W-50					→
	15W-40, 15W-50					→
	10W-40					→
	100W-30					

Loosen the screws of the side access panel to remove the cover.

Remove the dipstick with a clean rag to wipe the oil dipstick, without tightening the dipstick and insert it into the oil port to check the oil level.

If the oil level is below the bottom of the dipstick, add the recommended oil.

⚠ Be careful

- ◆ Operating the engine when the oil shortage may seriously damage the engine.
- ◆ Oil alert system will shut down the engine automatically before oil level falls under the safety line. But in order to avoid inconveniences caused by unexpected halt, we recommend you check the oil level regularly.

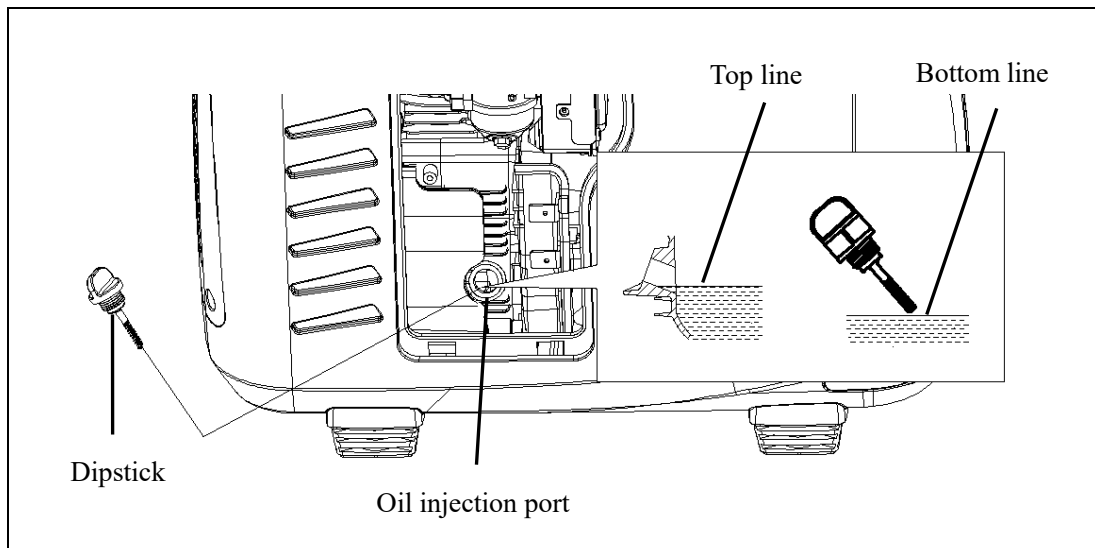

2. Check the fuel level

Use automotive gasoline (preferably unleaded or low-lead gasoline to reduce coke combustion and reduce environmental pollution).

When the fuel level is too low, add fuel to a predetermined level.

Do not use a mixture of oil and gasoline or dirty gasoline.

Prevent dirty, water into the tank.

After the completion of refueling tighten fuel cap.

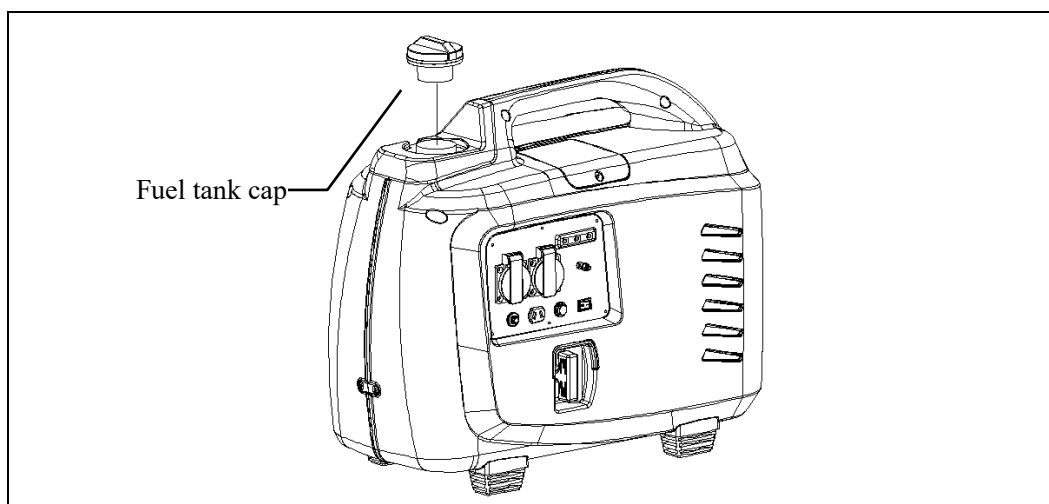

⚠ Warning

- ◆ Gasoline explosive under certain conditions.
- ◆ Please ventilation refueling, turn off the engine when refueling. Gasoline generator fuel storage area and the area is strictly prohibited fireworks.
- ◆ **Never add fuel when the generator is running, that's very dangerous.**
- ◆ Do not spill (there should be no fuel above the neck). After the completion of refueling tighten fuel tank cap.
- ◆ Be careful not to spill fuel when refueling, due to fuel spills or mist may ignite. If there is an overflow of fuel, shall ensure that the area of fuel has evaporated before starting the engine.
- ◆ Avoid prolonged, repeated exposure to gasoline or inhale mist. Do not let the reach of children.

3. Check the air filter

Check the air filter core, make sure it is clean and performance is normal.

- Split out the side access panel screws and open the side access panel.
- Remove the three captive screws on the air filter cartridge.
- As shown in the following diagram arrow and pull out the air filter drawer.
- Pull out the air filter drawer, check the air filter, clean or replace the filter if necessary.
- Clean or replace the filter before the reverse operation of installing air filtration devices.

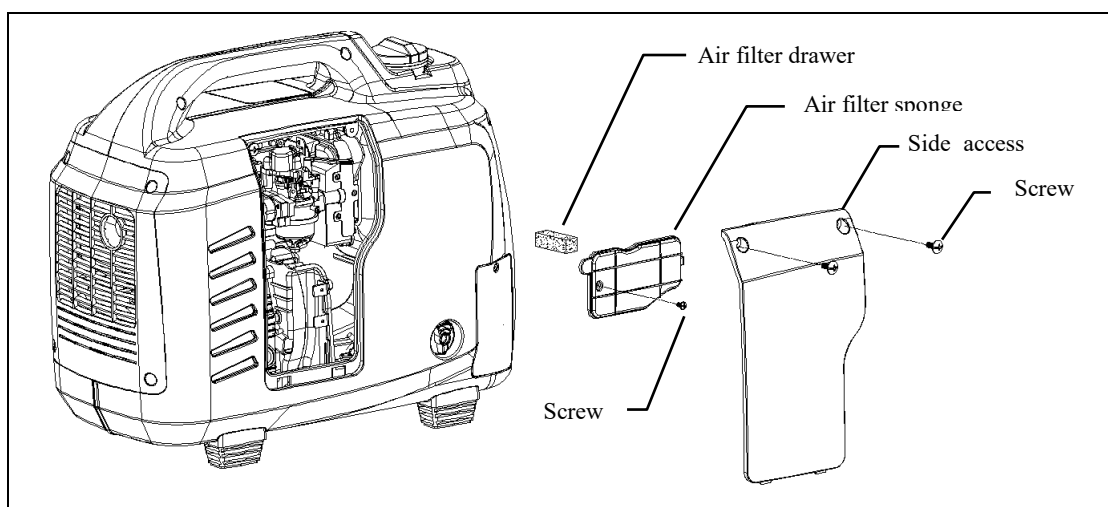

⚠ Be careful

- ◆ No filter does not allow the engine run, otherwise dirty will go into the engine through carburetor cause rapid wear of engine.

Empty cartridges lower part have a little amount of oil, which is a normal phenomenon, just wipe the oil off after stop.

6. Start the engine

Before starting the engine, disconnect the load on AC and DC socket.

1. Open the fuel switch

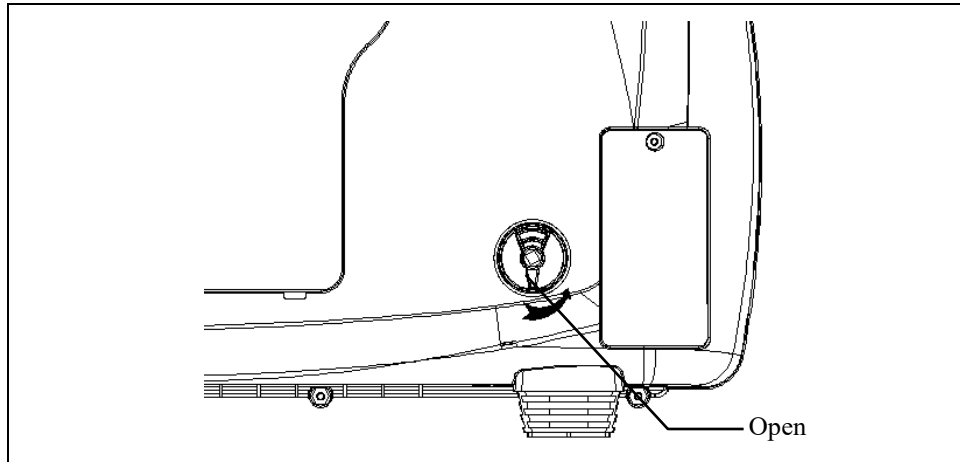

2. Press The start switch to the "ON" position

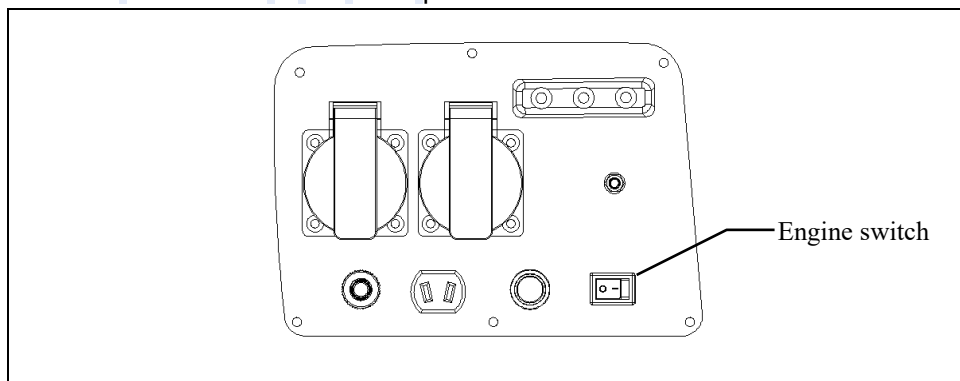

3. Pull the starter handle until you feel resistance, then pull the handle as the direction of the arrow in FIG quickly, start the generator.

⚠ Be careful

- ◆ It does not allow the starting handle to rebound, should slowly back into it.
- ◆ When pulling the starter cable, hold on the generator tightly to prevent generators lift overturned.

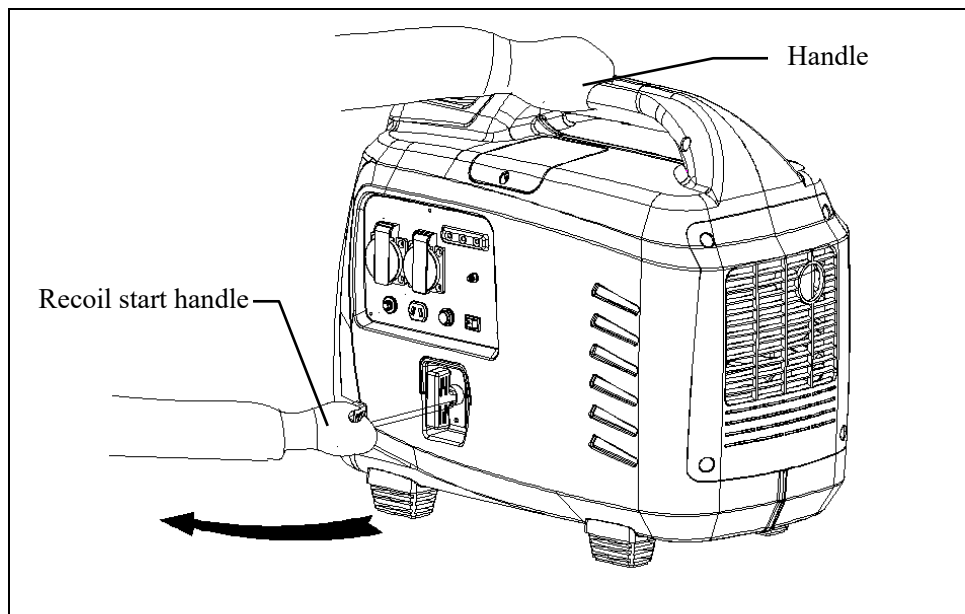

Operation at high altitudes

At high altitudes the standard carburetor air-fuel mixture more concentrated, reducing engine operating performance, and fuel consumption increases. Then you can place the carburetor main jet with a small one, and adjust the mixing ratio of the screw, you can change the engine performance in high altitude areas. If you always use the engine at an altitude of 1500 meters above area, please let authorized dealers to make changes to the carburetor.

Even use a suitable nozzle, engine horsepower will decrease by 3.5% as altitude increase every 305 meters. If you do not do these adjustments, the impact of altitude on power will be greater.

⚠ Be careful

- ◆ If the carburetor nozzles are designed for the high altitude, but operate at lower altitudes may cause decreased output power, overheating and even the air-fuel mixture is too thin and severe damage to the engine.

7. Use of the generator

Warning

- ◆ In order to prevent improper use of electric shock, the generator should be grounded. Between the ground terminal and an external ground source generator is connected by a thick cable.
- ◆ **When the generator is used as backup power to a building. It should be connected by a qualified electrician, and must comply with relevant laws and electrical codes. Otherwise, generator electricity may be back to the power line, it will electrocute utility workers or other people come into contact with the wire, and due to the impact of electricity, the generator may explode, burn or cause power system building on fire.**

Be careful

- ◆ When the generator continuous operation, do not exceed the rated power. If other cases, you should consider the total power of the connected device.
- ◆ Do not exceed the rated current of the socket.
- ◆ Do not take it for generator use can not be achieved, please observe the following additional requirements:
 - Do not paralleled generator
 - Do not lengthen the exhaust pipe
- ◆ If an extension cable, use a rubber sleeve flexible cable (the cable should meet the requirements of IEC245).
- ◆ Extension cable length limitation 2mm 2 cable length 60 m; 100 m cable length of 3mm 2.
- ◆ Generators should be away from other wires, cables, such as: distribution network

Note

- ◆ When using AC power, DC power can be used. If you want to use both AC and DC power supply, pay attention, do not exceed the sum of the power of the DC generator rated power.

AC power applications

1. Connect the ground terminal

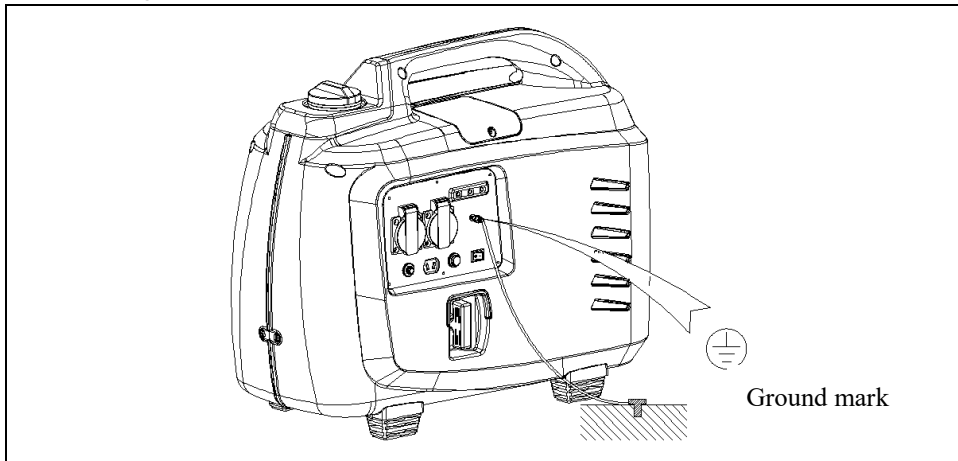

2. According to "start engine" requirement starts.
3. Ensure that the required device connected to the switch is turned off, and then plug in the machine at the generator outlet.

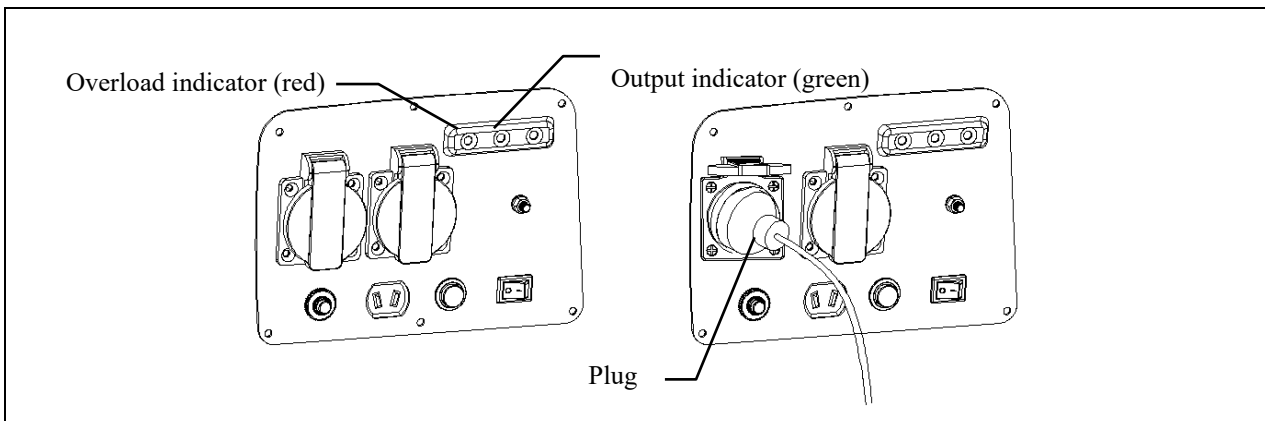

⚠ Be careful

- ◆ If the connected device before the connection is ON, it will suddenly start, causing injury.

4. When the output indicator (green) lights up, turn on the load.

If the internal overload operation or equipment failure, output indicator (green) will go out, the overload indicator light (red) will light up, and there is no power output, and the generator will not stop, you must press the engine start switch to "off" position to turn off the engine.

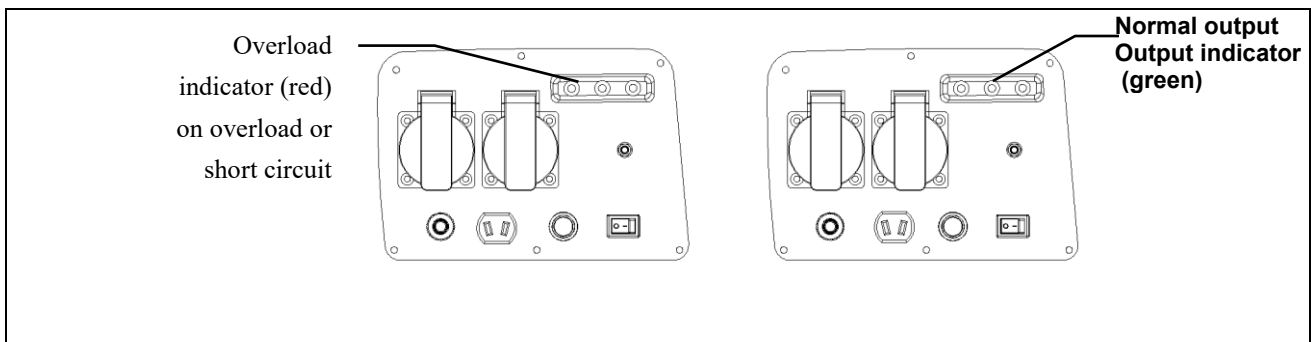

Output, overload indicator, oil warning light:

Under normal operating conditions, the output indicator light (green) will be lit.

If the generator is overloaded, an internal short circuit or connected equipment, the output indicator light (green) is off, and overload indicator (red) lights up. There is no output.

If the overload indicator light, first disconnect the device from the generator, check whether the device is faulty, whether there are problems with the connection line, turn off the power to the device, confirm that the reason why device overload, confirm and verify the reasons overload **has been resolved**, press reset switch on the panel, three seconds after the generator indicator will turn red to green, the generator begins normal output power.

If you press the reset switch, wait three seconds and the generator lights did not turn from red to green, then turn off the engine, then please contact an authorized dealer.

If the oil alarm lamp is lit, the engine will automatically shut down, then check to see if the oil should be added.

⚠ Note

- ◆ Before connect the device to the generator, check whether the device is in good condition, whether the required power exceeds the generator capacity, then connect the cable and start the generator.
- ◆ Make sure that the connected devices power switch is on “OFF” position.

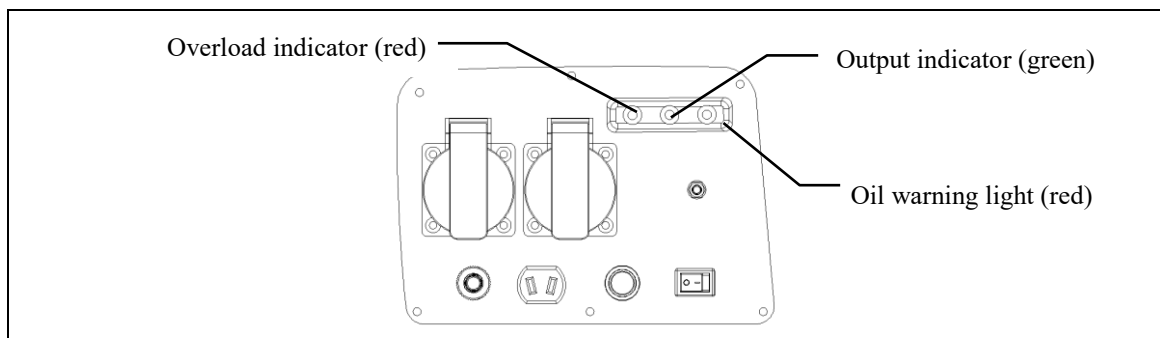

Pure inductive load with the machine with a pure inductive load, the machine can not be rated power with the same power, the machine rated power with only 40% to 75% pure inductive load.

Generator rated output

Altitude: 0 m Ambient temperature: 25 °C Relative Humidity: 30%

Only under specified ambient temperature and cooling, generator sets can be loaded to the rated power. If the working conditions do not meet the standards, as well as generators or poor engine cooling (run in a limited area), it should be appropriate to reduce the generator power.

Ambient Temperature Coefficient: C (30% RH)

Altitude(m)	Ambient Temperature(°C)				
	25	30	35	40	45
0	1	0.98	0.96	0.93	0.90
500	0.93	0.88	0.83	0.78	0.73
1000	0.87	0.82	0.77	0.72	0.67
2000	0.75	0.70	0.65	0.60	0.55
3000	0.64	0.59	0.54	0.49	0.44
4000	0.54	0.49	0.44	0.39	0.34

Note: When the relative humidity is 60%, the ambient temperature is improved coefficient of C-0.01

When the relative humidity is 80%, the ambient temperature is improved coefficient of C-0.02

When the relative humidity is 90%, the ambient temperature improved coefficient of C-0.03

When the relative humidity is 100%, the ambient temperature improved coefficient of C-0.04

Algorithms Example:

When the generator power rating $P_N = 2.0$ KW, altitude is 1000m, the ambient temperature is 35 °C, relative humidity is 80%, and in this environment the generator rated output of $P = P_N \times (C - 0.02) = 2.3 \times (0.77 - 0.02) = 1.5$ KW

DC use:

DC output is for 12V automatic battery charging only.

Note

- ◆ When the DC socket charge for battery, must be present to monitor the battery voltage, if the battery voltage exceeds 16V, then you must immediately stop punching power. Otherwise may cause battery overcharge fire or explosion.

1. The charging cable is connected to the generator DC socket, and then connect to the battery terminals.

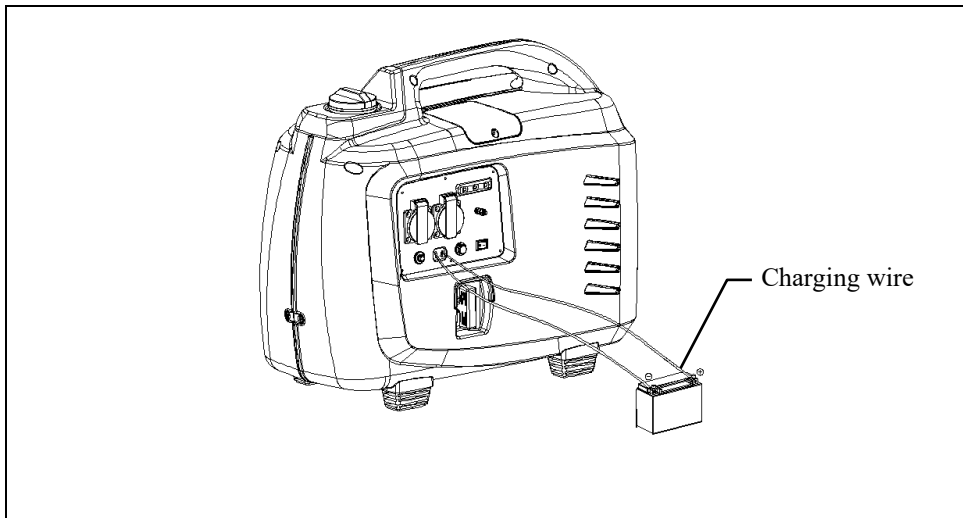

⚠ Warning

- ◆ Charging first charging cable is connected to the battery, and then connected to the generator and remove the generator shall commence from the end, then to the battery which prevents sparks.
- ◆ When the charging cable is connected to a battery mounted on the car, disconnect the battery ground cable. After completion of the charging cable to remove the battery and then connect the ground wire, so even in case I the battery terminals and car frame contact can prevent a short circuit or spark

⚠ Warning

- ◆ Do not start the car when the generator connect to battery, otherwise it will damage the generator
- ◆ Battery charge cable and wiring polarity should be correct, otherwise it will damage the generator or battery

⚠ Warning

- ◆ During charge should provide proper ventilation and away from the fireworks, because the battery will be volatile flammable gases.
- ◆ The battery contains sulfuric acid (electrolyte), contact with skin or eyes may cause burns, wear protective clothing and masks.
 - Toxic electrolyte, the electrolyte if splashed on skin, immediately rinse with clean water.
 - If electrolyte is splashed in the eyes, immediately rinse for 15 minutes with clean water and go to the hospital to see a doctor.
- ◆ If you accidentally swallow electrolyte, wash immediately with plenty of drinking water or milk, plus a drink magnesia milk or vegetable oil, and go to the hospital to see a doctor.
- ◆ And battery electrolyte should be placed out of reach of children.

2. Start the engine

When using alternating current, direct current can be used simultaneously.

DC overloads may cause DC protection to protect, and you should make the switch to reset.

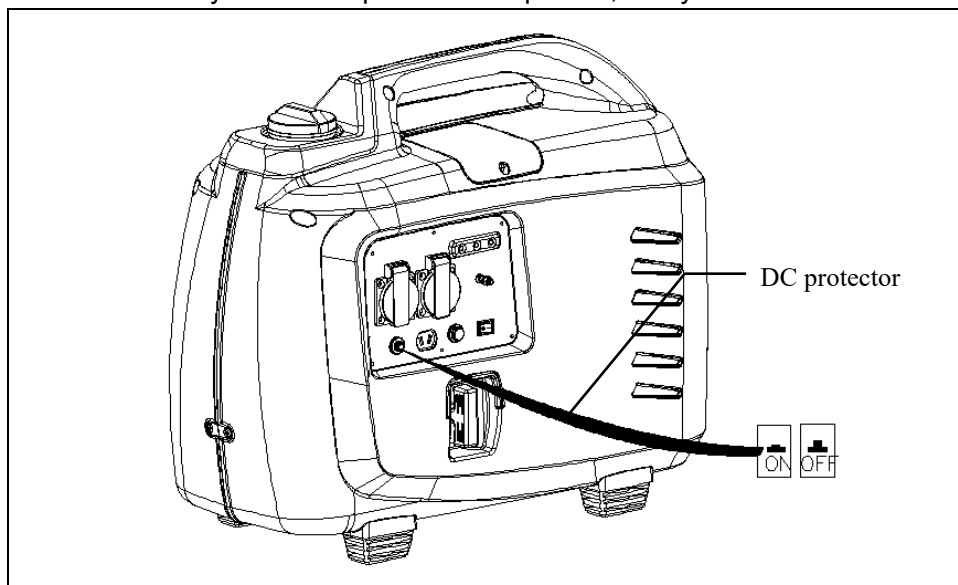

Oil alarm system

Oil Alert system is designed to prevent engine damage due to lack of lubricant. Before the crankcase oil fell to the safety line, oil alarm system will automatically shut down the engine (although start switch remains in the "on" position).

Oil alarm system turned off the engine if you try to start the engine again, oil warning light (red) will brief flashes when the engine is no longer running. If this happens, add oil (see 4.1 filling method)

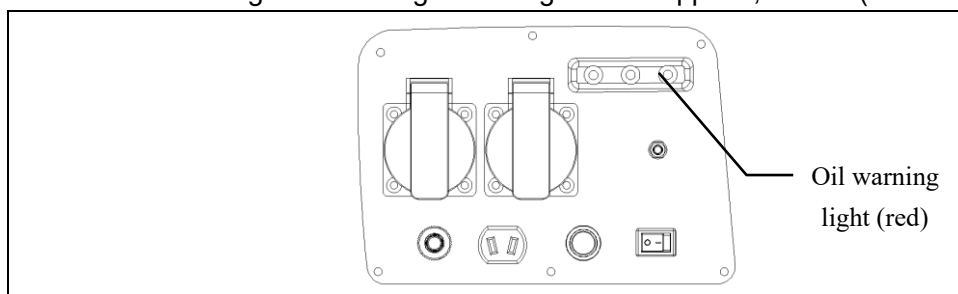

8. Switch off the engine

If need emergency shutdown the engine, turn the start switch to the 'OFF' position.

Normal use:

1. Turn off the connected equipment, pull out the plug.

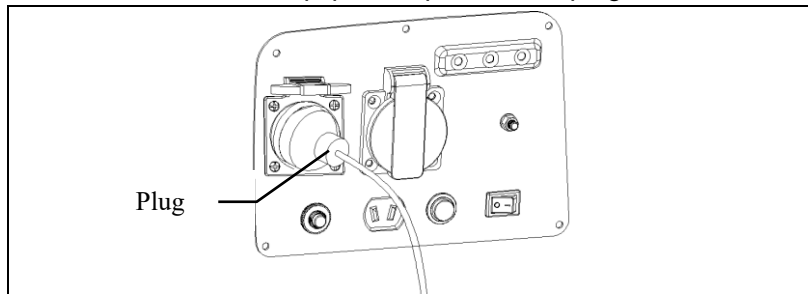

2. Turn the start switch to the 'OFF' position.

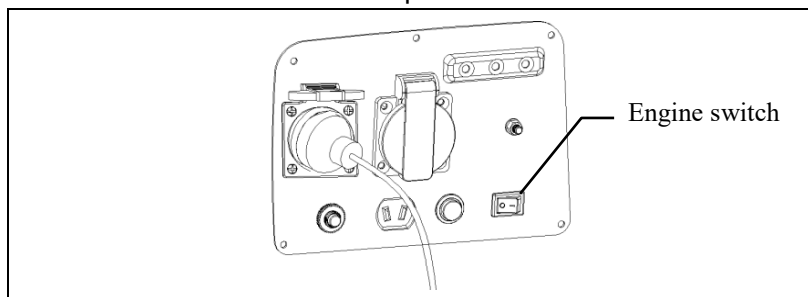

3. Turn the fuel switch to the 'OFF' position.

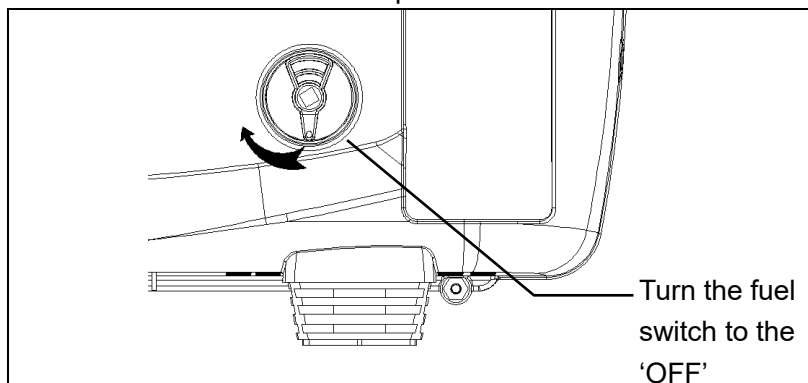

9. Maintenance

Maintenance and adjustment schedule was developed to enable the generator in the best working condition.

⚠ Warning

- ◆ Turn off the engine before any repairs, the engine must be running in the ventilation if repairs need the engine on because exhaust contains poisonous carbon monoxide.

⚠ Be careful

- ◆ Please use genuine parts, the use of inferior parts can damage the engine.

Maintenance schedule

Repair it within a specified month or hour, Month or hour are optionally.

Project	Periodic maintenance time (1)	Each use	Per month or 20 hours	Every 3 month or 50 hours	Every 6 month or 100 hours	Per year or 300 hours
Engine oil	an examination	○				
	Replace		○			
Air filter	an examination	○				
	Clean			○ (2)		
Muffler Anti-Fire	an examination	○				
	Clean		○			
Spark plug	Cleaning-Adjustment				○	
Fuel sediment bowl	Clean				○	
Lash	Cleaning-Adjustment					○ (3)
Fuel tank and filter	Clean					○ (3)
Fuel line	an examination	Every two years [If necessary, change (3)]				

Note: (1)Normal maintenance intervals;

(2)Use in heavily polluted areas, please regular inspection and maintenance

(3)Regular maintenance schedule above is calculated according to the ambient temperature of 25 °C, if the ambient temperature exceeds 30 °C, please respective load power or shorten the oil change intervals (two optional one operation) to reduce the generator.

1. Oil change

When the engine is a heat engine, can discharge oil quickly and thoroughly.

- ◆ In order to meet environmental requirements, we recommend put the waste oil in a sealed container and send to your local service station and recycling center. Do not pour oil on the ground or in the trash.

2. Air filter maintenance

Dirty air filter can block the airflow into the carburetor to prevent carburetor malfunction, maintenance of air filters regularly, especially if you frequently use a generator in a dirty place, require frequent maintenance.

⚠ Warning

- ◆ Do not use gasoline or low flash point solvents to clean the generator because they are flammable and explosive under certain conditions.

Check the air filter core, make sure it is clean and properties of normal

- Split out the side access panel screws and open the side access panel.
- Remove the three captive screws on the air filter cartridge.
- As shown in the following diagram arrow and pull out the air filter drawer.
- Pull out the air filter drawer, check the air filter, if necessary, clean or replace the filter
- Clean or replace the filter before the reverse operation of installing air filtration devices.

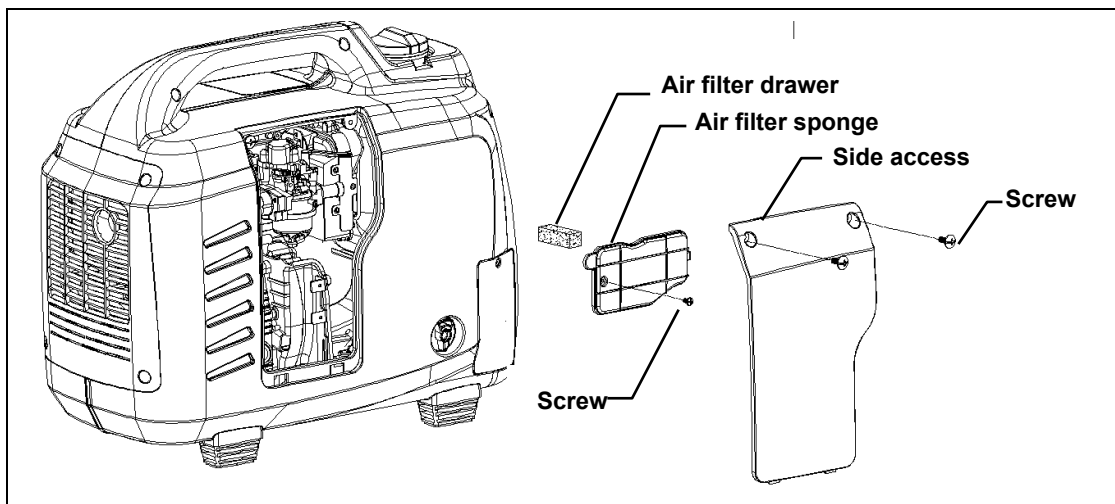

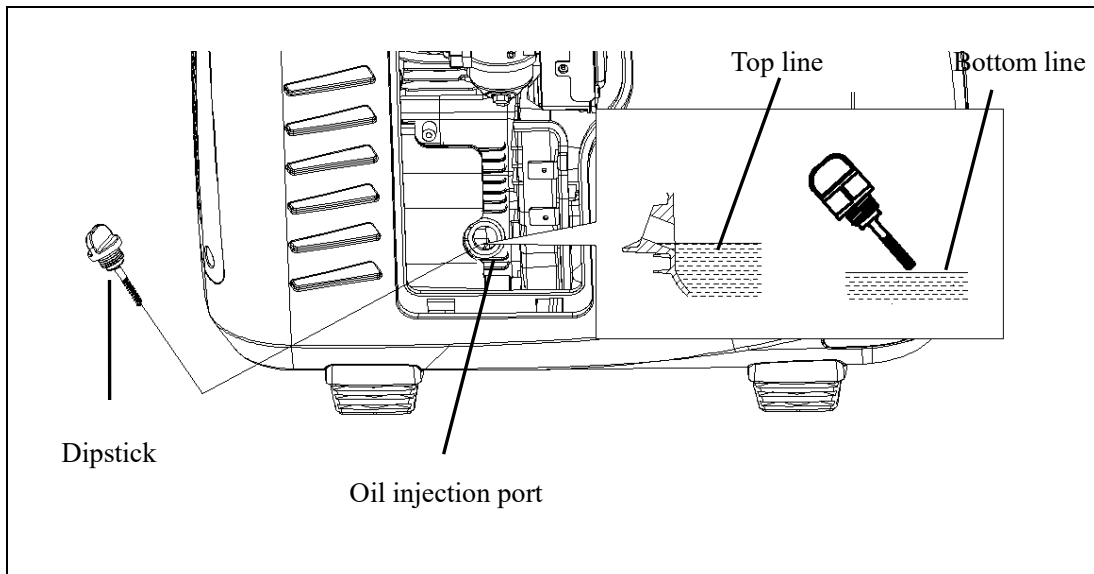

After contact with the oil, please wash your hands with soap and water.

⚠ Be careful

- ◆ In order to meet environmental requirements, we recommend put the waste oil in a sealed container and send to your local service station and recycling center. Do not pour oil on the ground or in the trash.

3. Air filter maintenance

Dirty air filter can block the airflow into the carburetor to prevent carburetor malfunction, maintenance of air filters regularly, especially if you frequently use a generator in a dirty place, require frequent maintenance.

Warning

- ◆ Do not use gasoline or low flash point solvents to clean the generator because they are flammable and explosive under certain conditions.

Check the air filter core, make sure it is clean and properties of normal

- Split out the side access panel screws and open the side access panel.
- Remove the three captive screws on the air filter cartridge.
- As shown in the following diagram arrow and pull out the air filter drawer.
- Pull out the air filter drawer, check the air filter, if necessary, clean or replace the filter
- Clean or replace the filter before the reverse operation of installing air filtration devices.

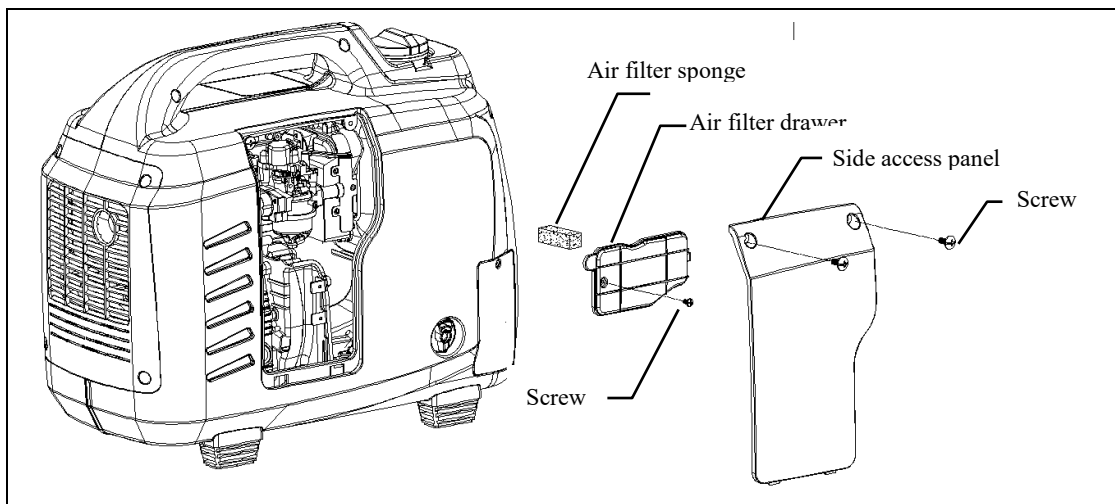

4. Spark plug maintenance

Recommended spark plug(NGK):

In order to ensure the normal operation of the engine, the spark plug gap must be appropriate, no spark plugs coke.

- 1) Remove the top access panel screws and remove the top access panel
- 2) Pull the ignition coil out.
- 3) Remove the spark plug with a spark plug socket.

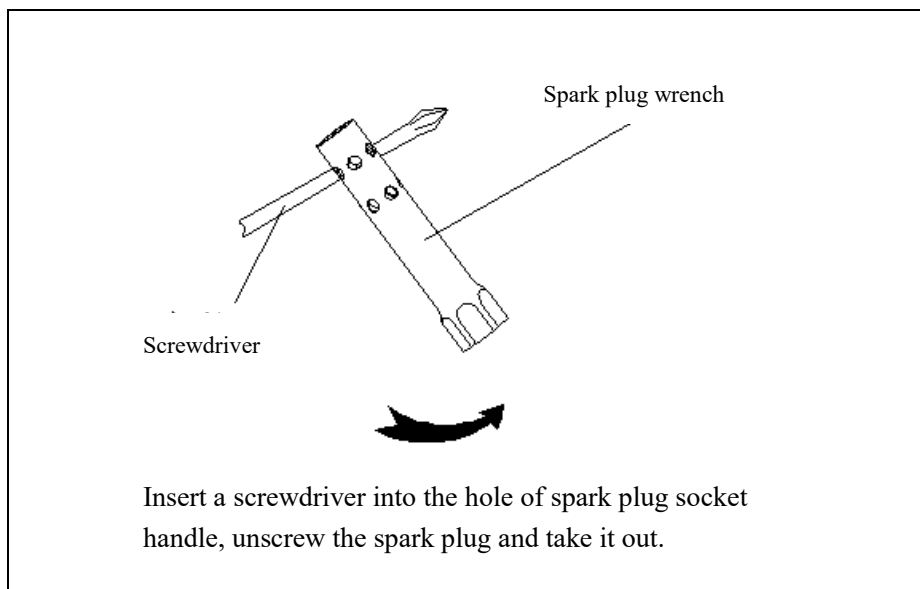
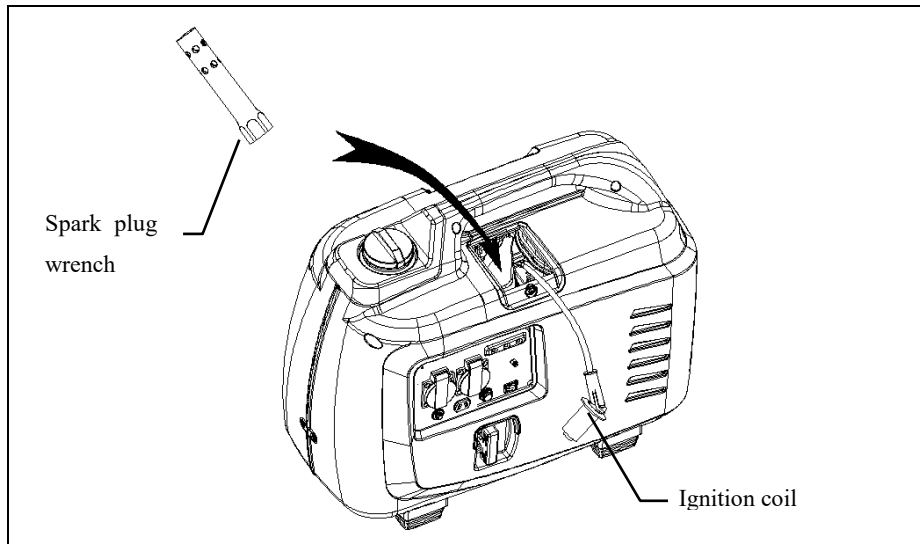

- 4) Visual spark plug if the insulator has been broken, must be discarded, if you want to use the spark plug again, use a brush to clean the spark plug.
- 5) Measure spark plug gap with a feeler gauge, the spark plug gap should be 0.6-0.7mm(0.024-0.028in)

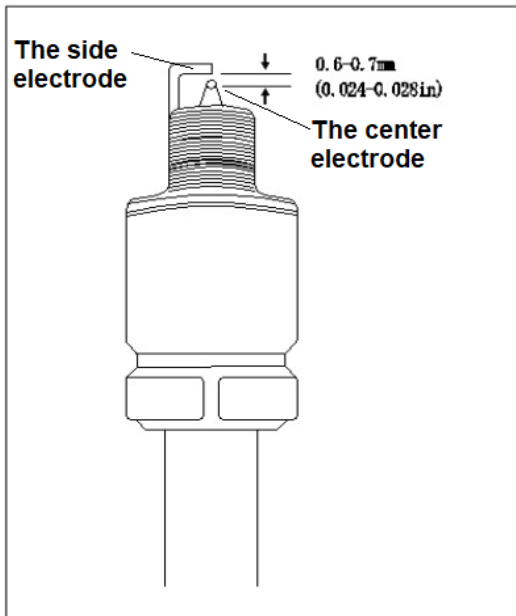

- 6) Manually install the spark plug carefully, be careful not to screw dislocation.
- 7) After manually installing a new spark plug, tighten 1/2 turn with a wrench, and a good pressure washer. If it is a used spark plug inspection can still be used, then it simply after positioning with a wrench and tighten 1/4 to 1/8 can.
- 8) Re-install the ignition coil.
- 9) Re-install the top access panel.

⚠ Be careful

- ◆ The spark plug must be securely installed, otherwise spark plug gets hot damage the generator.
- ◆ Do not use different heating value spark plugs.

4. Fire prevention muffler maintenance and cleaning

Dirty muffler will affect the muffling effect and the engine power. To ensure the normal operation of the generator, periodically clean up the muffler flame screens, if you use the generator in extremely dirty place frequently. Please replace the muffler flame screens if necessary.

⚠ Be careful

- ◆ Engine must be turned off when cleaning the generator muffler flame screens
- ◆ Make sure to check the engine muffler when the machine is cold, otherwise hot muffler can cause burns.

- a. Split out the hood screws to open the outlet cover plate
- b. Remove the two fixing screws on the muffler
- c. Take out the muffler flame screen as shown below.
- d. Check the flame screen, clean or replace if necessary.
- e. After clean or replace the flame screen, install the wind cover with the reverse action.

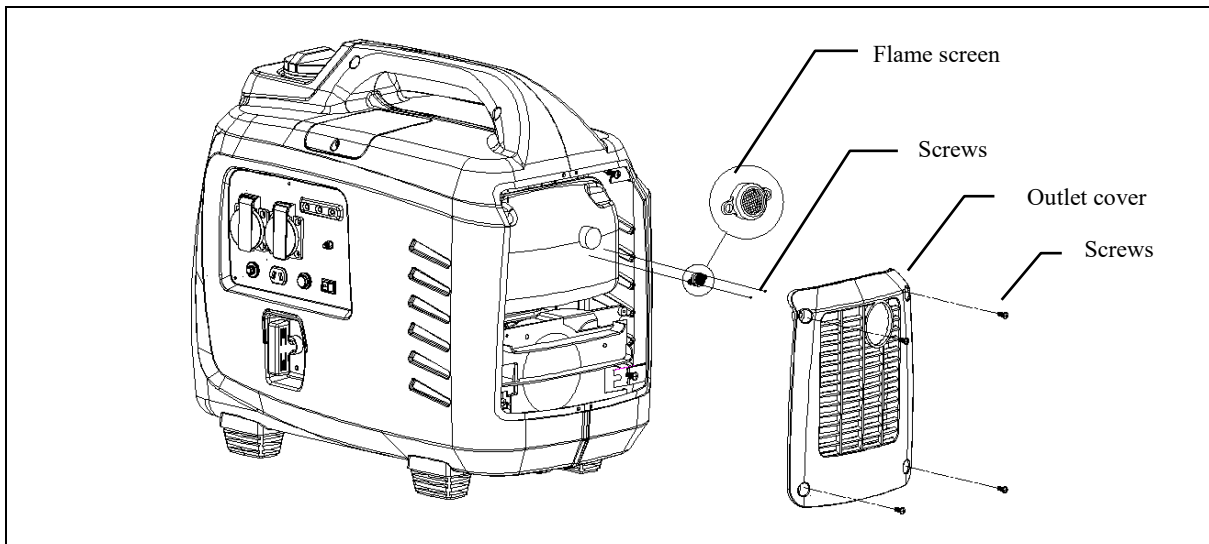

10. Transportation/Warehousing

⚠ Warning

When transporting the generator:

- ◆ Do not fill too much fuel.(Filler should be no fuel)
- ◆ Make sure the fuel switch is off.
- ◆ When transporting the generator should be fixed firmly to prevent rollover.
- ◆ When the generator is still on the means of transport, do not operate the generator, the generator is removed from the transport, use it in a well-ventilated place.
- ◆ When put the generator into means of transport, should be avoided on too much direct sunlight. If the generator placed inside a sealed compartment inside the high temperature may lead to volatile fuel, causing an explosion.
- ◆ Do not long transport the generator on a rough road, if you had to do so, before shipping drain the generator.

Before generator long time storage:

- 1) Make sure storage areas dry and clean.
- 2) Drain the fuel.

⚠ Warning

- ◆ Under certain conditions, extremely flammable gas, stored in a generator may not contain emission clean fuel, so the regional storage and transport of the generator should be prohibited fireworks

1. Drain all gasoline into a container. Open the fuel switch, start the engine run till the engine shut off automatically after out of fuel.

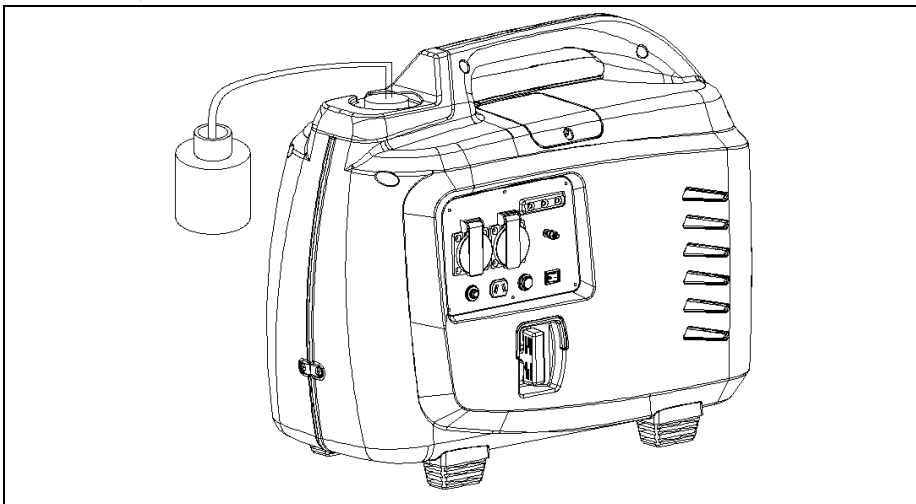

2. Drain oil
3. Remove the spark plug, pour a tablespoon of clean engine oil to the cylinder, pulling the handle several times to start bulk oil spill, and then install the spark plugs
4. Slowly pull the handle to feel the pressure, at that time, the piston being raised to the top of its compression stroke, the exhaust valves are closed. In this case the internal storage helps prevent the engine from rusting

11. Troubleshooting

Engine does not start

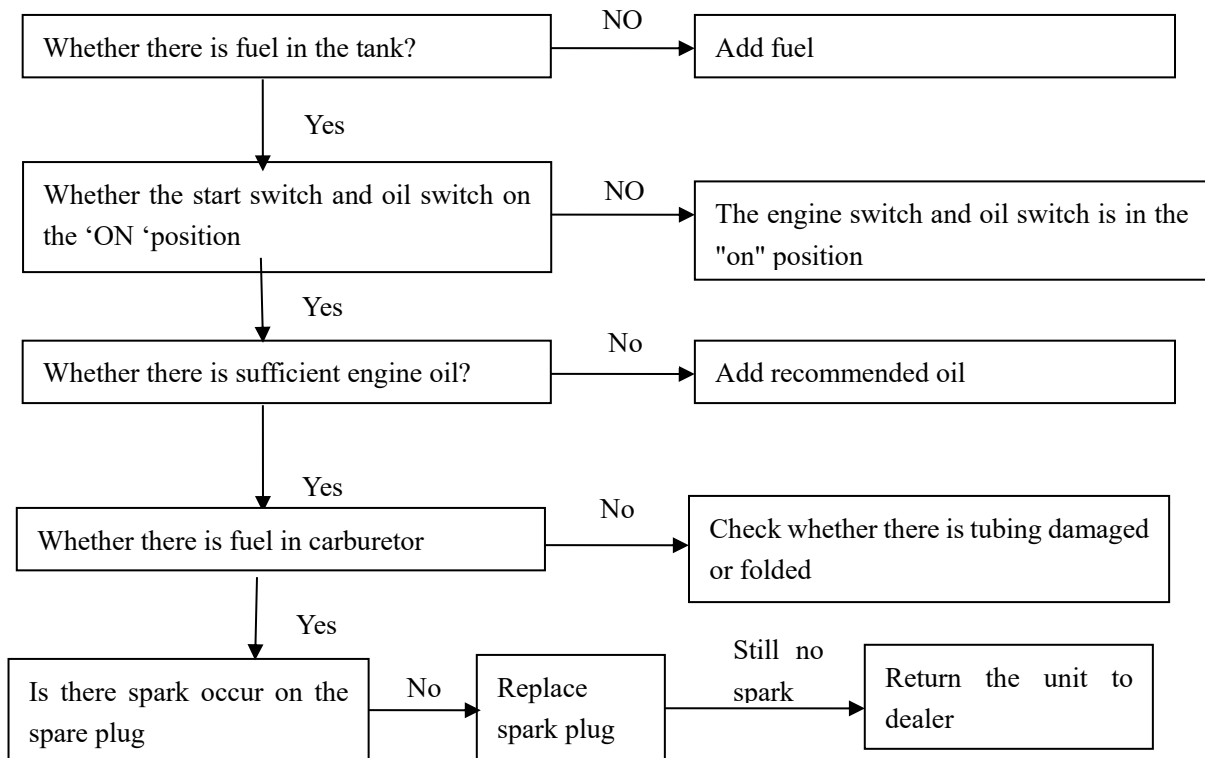

Note

- ◆ If this is the first time add oil and oil renewal after the generator can not be started and pulling the starting handle oil warning light flashes. Shake the generator side to side a few times to ensure that the oil alarm float float. If you still can not start the generator, please follow the above troubleshooting methods to troubleshoot.

Examination

Carburetor

1. Pull off the fuel tube at the bottom of carburetor cup which connected to fuel injector. There should be fuel flew out.
2. After checking replacing the tubing, the tube clip must be effectively jammed fuel port.

Spark plugs

1. Remove the ignition coil, clean the dirt around the spark plug.
2. Remove the spark plug, install the spark plug into ignition coil.
3. Ground the spark plug side electrode with a wire connect to the engine's metal parts. (Can ground with the DC charge wire. Use one clip clip on metal parts, the other end of the same polarity connect to the spark plug side electrode.
4. Pull the starter handle, there should be spark between the gap.

⚠ Note

- ◆ Make sure to check the spark plug when the engine is cold, otherwise hot engine and spark plug can cause burns.
- ◆ Make sure that no fuel spill around the spark plug, spilled fuel could catch fire.

Generator connected device does not start

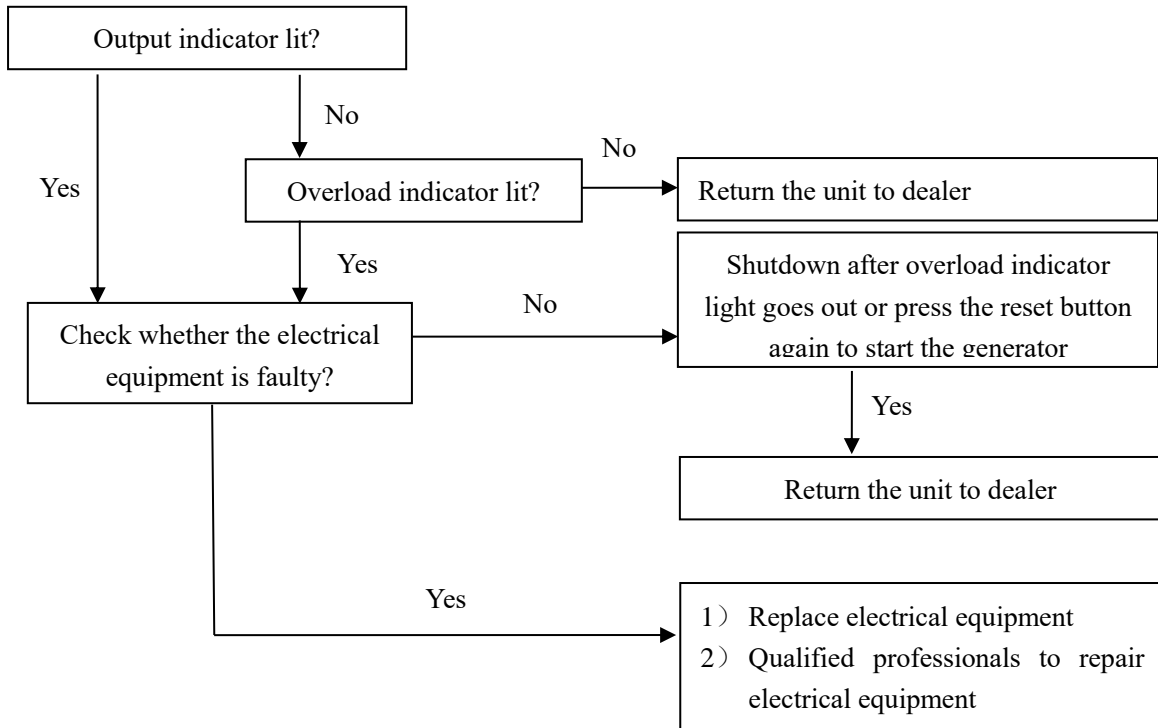

DC socket without electricity

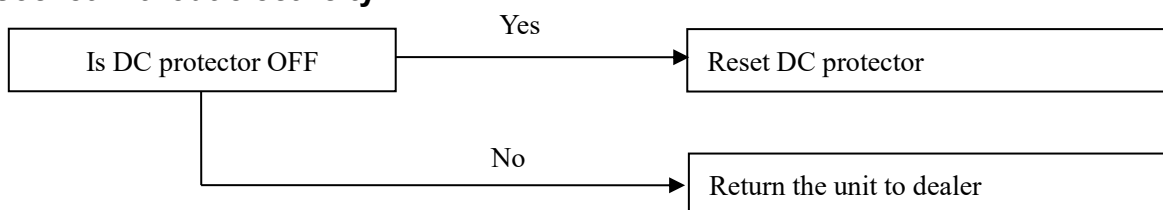

Power shortage

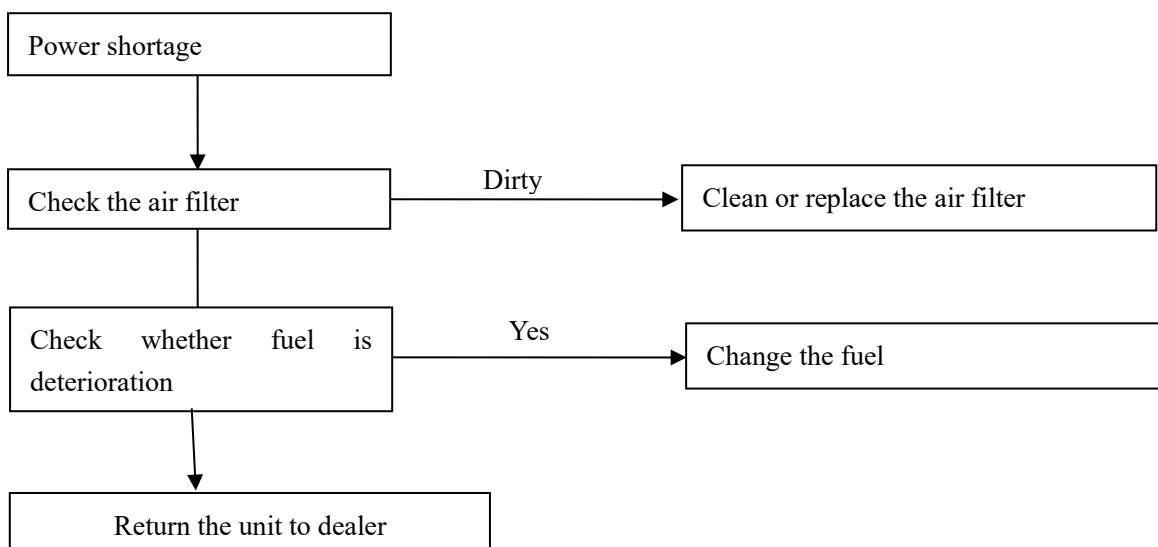

12. Specifications

Specification

Dimensions and weight Is DC protector OFF

Model No.	HG3300I
Length x Width x Height (mm)	575×302×488mm
Net weight(Kg)	25

Engine

Model No.	XG157F
Engine type	4-stroke, overhead valve, single cylinder machine
Displacement	149cc
Rating speed	5000/min
Compression ratio	8.5
Cooling system	Air cooled
Oil capacity	0.45L
Fuel tank capacity	7.0L
Spark plug	A7RTC
Noise Level (7m Away)	58db
Sound pressure level L_{PA}	68.25dB(A), K= 3dB
Sound pressure level L_{WA}	88.25 dB(A), K= 3dB
The declared guaranteed sound power level LWA (According to Directive 2000/14/EC)	90dB(A)

Generator

Model No.		HG3300I
AC output	Rated voltage (V)	230
	Rated frequency (Hz)	50
	Rated current (A)	13.5
	Power factor (cos Φ)	1.0
	Rated power (kW)	COP 3.1kw
	Max power (kW)	MAX 3.3 kw
DC output	12V/8.3A	For 12V automatic battery use only

13. CE DECLARATION

CE Declaration of conformity

BUILDER

ZI, 32 RUE ARISTIDE BERGES – 312070 CUGNAUX – FRANCE

Declares that the machinery designated below :

GENERATOR PETROL INVERTER

Modle : *HG3300I*

Serial number : 20210862391-20210862640

Complies with the provisions of the Directive « machinery » 2006/42/EG and national laws transposing it :

Also complies with the following European directives :

EMC Directive 2014/30/EC

ROHS Directive (EU)2015/863 amending 2011/65/EU

Emission directive (EU) 2016/1628 & 2018/989/EU

Noise directive 2000/14/CE Annex VI + 2005/88/CE

Sound pressure level L_{pA} : 68.25 dB(A)

Sound power level L_{WA} 88.25 dB(A)

Guaranteed sound power level:90dB(A)

Noise certificate issued by : Intertek Testing & Certification Ltd. (Notified Body 0359)

Davy Avenue, Knowlhill, Milton Keynes, MK5 8NL

Also complies with European standards, with national standards and the following technical provisions :

EN 8528-13 : 2016

EN 55012:2007/+A1:2009

EN 61000-6-1:2007

Done at Cugnaux, 01/08/2021



Philippe MARIE / PDG

14. WARRANTY

HYUNDAI

WARRANTY

The manufacturer guarantees the product against defects in material and workmanship for a period of 2 years from the date of the original purchase. The warranty only applies if the product is for household use. The warranty does not cover breakdowns due to normal wear and tear.

The manufacturer agrees to replace parts identified as defective by the designated distributor. The manufacturer does not accept responsibility for the replacement of the machine, in whole or in part, and/or ensuing damage.

The warranty does not cover breakdowns due to:

- insufficient maintenance.
- abnormal assembly, adjustment or operations of the product.
- parts subject to normal wear and tear.

The warranty does not extend to:

- shipping and packaging costs.
- using the tool for a purpose other than that for which it was designed.
- the use and maintenance of the machine done in a manner not described in the user manual.

Due to our policy of continuous product improvement, we reserve the right to alter or change specifications without notice. Consequently, the product may be different from the information contained therein, but a modification will be undertaken without notice if it is recognized as an improvement of the preceding characteristic.

READ THE MANUAL CAREFULLY BEFORE USING THE MACHINE.

When ordering spare parts, please indicate the part number or code, you can find this in the spare parts list in this manual. Keep the purchase receipt; without it, the warranty is invalid. To help you with your product, we invite you to contact us by phone or via our website:

- **+33 (0)9.70.75.30.30**
- **<https://services.swap-europe.com/contact>**

You must create a "ticket" via the web platform.

- Register or create your account.
- Indicate the reference of the tool.
- Choose the subject of your request.
- Describe your problem.
- Attach these files: invoice or sales receipt, photo of the identification plate (serial number), photo of the part you need (for example: pins on the transformer plug which are broken).



15. PRODUCT FAILURE

WHAT TO DO IF MY MACHINE BREAKS DOWN?

If you bought your product in a store:

- a) Empty the fuel tank.
- b) Make sure that your machine is complete with all accessories supplied, and clean! If this is not the case, the repairer will refuse the machine.

Go to the store with the complete machine and with the receipt or invoice.

If you bought your product on a website:

- a) Empty the fuel tank.
- b) Make sure that your machine is complete with all accessories supplied, and clean! If this is not the case, the repairer will refuse the machine.
- c) Create a SWAP-Europe service ticket on the site: <https://services.swap-europe.com> When making the request on SWAP-Europe, you must attach the invoice and the photo of the nameplate (serial number).
- d) Contact the repair station to make sure it is available before dropping off the machine.

Go to the repair station with the complete machine packed, accompanied by the purchase invoice and the station support sheet downloadable after the service request is completed on the SWAP-Europe site

For machines with engine failure from manufacturers BRIGGS & STRATTON, HONDA and RATO, please refer to the following instructions.

Repairs will be done by approved engine manufacturers of these manufacturers, see their site:

- <http://www.briggsandstratton.com/eu/fr>
- <http://www.honda-engines-eu.com/fr/service-network-page;jsessionid=5EE8456CF39CD572AA2AEEDFD290CDAE>
- <https://www.rato-europe.com/it/service-network>

Please keep your original packaging to allow for after-sales service returns or pack your machine with a similar cardboard box of the same dimensions.

For any question concerning our after-sales service you can make a request on our website <https://services.swap-europe.com>

Our hotline remains available at +33 (9) 70 75 30 30.



16. WARRANTY EXCLUSIONS

THE WARRANTY DOES NOT COVER:

- Start-up and setting up of the product.
- Damage resulting from normal wear and tear of the product.
- Damage resulting from improper use of the product.
- Damage resulting from assembly or start-up not in accordance with the user manual.
- Breakdowns related to carburetion beyond 90 days and fouling of carburetors.
- Periodic and standard maintenance events.
- Actions of modification and dismantling that directly void the warranty.
- Products whose original authentication marking (brand, serial number) has been degraded, altered or withdrawn.
- Replacement of consumables.
- The use of non-original parts.
- Breakage of parts following impacts or projections.
- Accessories breakdowns.
- Defects and their consequences linked to any external cause.
- Loss of components and loss due to insufficient screwing.
- Cutting components and any damage related to the loosening of parts.
- Overload or overheating.
- Poor power supply quality: faulty voltage, voltage error, etc.
- Damages resulting from the deprivation of enjoyment of the product during the time necessary for repairs and more generally the costs related to the immobilization of the product.
- The costs of a second opinion established by a third party following an estimate by a SWAP-Europe repair station
- The use of a product which would show a defect or a breakage which was not the subject of an immediate report and/or repair with the services of SWAP-Europe.
- Deterioration linked to transport and storage*.
- Launchers beyond 90 days.
- Oil, petrol, grease.
- Damages related to the use of non-compliant fuels or lubricants.

* In accordance with transport legislation, damage related to transport must be declared to carriers within 48 hours maximum after observation by registered letter with acknowledgement of receipt.

This document is a supplement to your notice, a non-exhaustive list.

Attention: all orders must be checked in the presence of the delivery person. In case of refusal by the delivery person, it you must simply refuse the delivery and notify your refusal.

Reminder: the reserves do not exclude the notification by registered letter with acknowledgement within 72 hours.

Information:

Thermal devices must be wintered each season (service available on the SWAP-Europe site). Batteries must be charged before being stored.

HYUNDAI

POWER PRODUCTS

For Inquiries, please contact:

BUILDER SAS

32, Rue Aristide Bergès Z1 31270 Cugnaux, France

Tél.: +33(0)5.34.502.502 Fax : +33(0)5.34.502.503

<http://www.hyundaipower-fr.com/>

Fabriqué en République Populaire de Chine(PRC)